



KITS



PUMPEN



ZÄHLER



ZAPFVENTILZÄHLER



ZAPFVENTILE



ALTÖLAUSRÜSTUNG

VISCOMAT VANE

MERKMALE

- EINSTELLBARER BYPASS
- MEHRZWECKPUMPE
- GEEIGNET ZUR ALTÖLÜBERGABE

Die PIUSI VISCOMAT VANE ist eine Elektro-Flügelzellenpumpe für die Beförderung von Flüssigkeiten geringer und mittlerer Viskosität. Die Pumpe ist mit einem integrierten einstellbaren Bypass ausgestattet.

LEISTUNGSPARAMETER

BIS ZU

50 L/MIN

VOLUMENSTROM

AC

SPANNUNG

LEISTUNG

UNTER

77 DB

GERÄUSCHPEGEL

BIS ZU

500

CST

VISKOSITÄT



VISCOMAT VANE



VERPACKUNG

| CODE | GEWICHT | | VERPACKUNG | | | | |
|------|---------|-----|------------|------|---------------|--------------|--|
| | KG | LBS | MM | ZOLL | STCK./PALETTE | STCK./KARTON | |

VISCOMAT 70

| | | | | | | | |
|-----------|-------|------|-------------|---|----|----|---|
| FO033490A | 14,15 | 31,1 | 355X185X285 | - | 60 | 72 | 1 |
| FO033190A | 14,15 | 31,1 | 350X200X280 | - | 60 | 72 | 1 |

VISCOMAT 90

| | | | | | | | |
|-----------|-------|------|-------------|---|----|----|---|
| FO0303MOO | 14,15 | 31,1 | 350X200X280 | - | 60 | 72 | 1 |
| OO0303000 | 14,15 | 31,1 | 350X200X280 | - | 60 | 72 | 1 |



FILTERUNG



ÖLÜBERWACHUNG



TANKÜBERWACHUNG



SCHLAUCHAUFRÖLLER



ZUBEHÖR



MERCHANDISE



LUFT



FROSTSCHUTZ



AdBlue®



BIODIESEL



DIESEL



LEBENS.M.



BENZIN



SCHMIERM.



KEROSIN



ÖL



WASSER



WISCHERFLÜSS.

KENNLINIEN

LIEFERUMFANG

- PUMPEVISCOMAT VANE
- BEDIENUNGSANLEITUNG

EINZELHEITEN

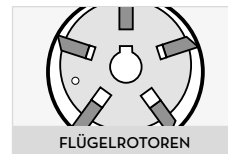

FLÜGELROTOREN



EIN/AUS-SCHALTER

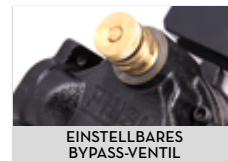

EINSTELLBARES BYPASS-VENTIL

MATERIALIEN

- GEHÄUSE: GUSSEISEN
- ROTOR: SINTERSTAHL
- FLÜGELZELLEN: TECHNOPYLIMER
- WELLE: STAHL

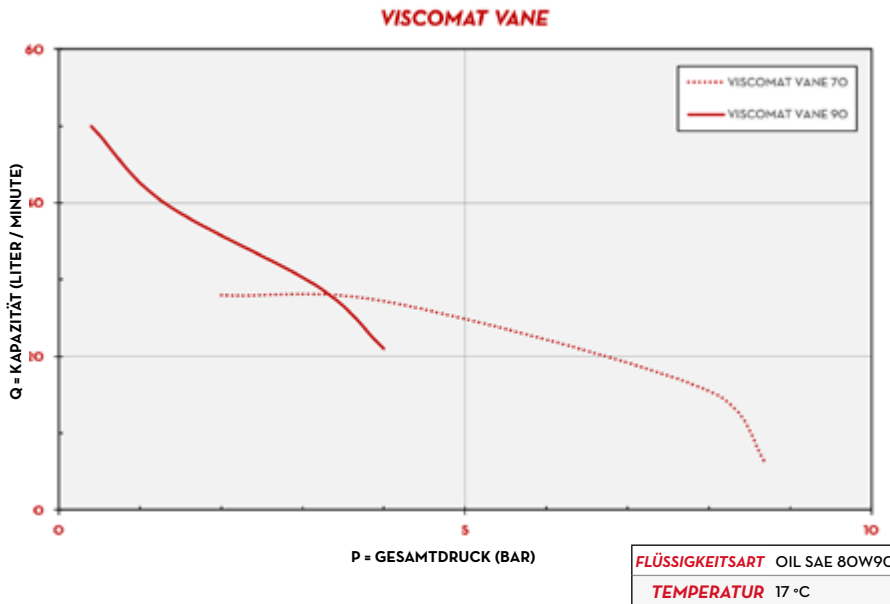

ABMESSUNGEN

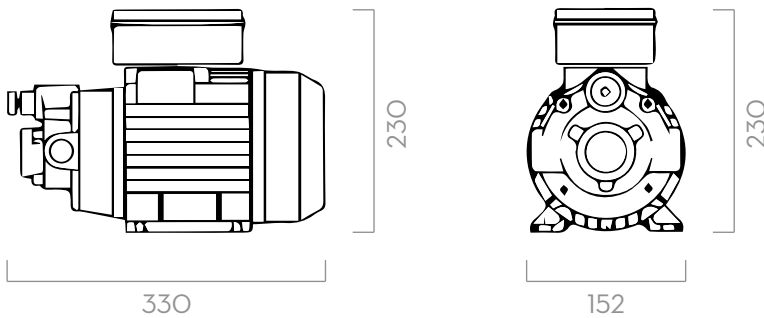

Maße in Millimetern

TECHNISCHE DATEN

| CODE | BESCHREIBUNG | FLÜSSIGKEITSART | VOLUMENSTROM | | LUFTDRUCK | | SPANNUNG | | | | DREHZAHL | EINLASS/AUSLASS BSP | BYPASSVENTIL |
|--------------------|---------------------------|-----------------|--------------|-----|-----------|-----|------------------------|-------------------------|------------|----------|-----------|---------------------|--------------|
| | | | L/MIN | GPM | BAR | PSI | EINPHASIGER MOTOR V/Hz | DREIPHASIGER MOTOR V/Hz | POWER WATT | AMP. MAX | | | |
| VISCOMAT 70 | | | | | | | | | | | | | |
| FO033490A | VISCOMAT 70 M. 230/50/60 | ⊙ ⊕ | 25 | 7 | 6 | 85 | 230/50/60 | - | 1200/1000 | 5,5-5,1 | 1470/1650 | 1" BSP | JA |
| FO033190A | VISCOMAT 70 T. 400/50/60 | ⊙ ⊕ | 25 | 7 | 6 | 85 | - | 400/50 - 460/60 | 650/1000 | 2,2/3,1 | 1470/1750 | 1" BSP | JA |
| VISCOMAT 90 | | | | | | | | | | | | | |
| FO0303M00 | VISCOMAT 90 M. 230/50/60* | ⊙ ⊕ | 50 | 13 | 5 | 71 | 230/50/60 | - | 1350/1600 | 6,2/4,9 | 1400/1600 | 1" BSP | NEIN |
| 000303000 | VISCOMAT 90 T. 400/50 | ⊙ ⊕ | 50 | 13 | 5 | 71 | - | 400/50 | 2000 | 5 | 1450 | 1" BSP | JA |

AUF ANFRAGE AUCH MIT UNTERSCHIEDLICHER SPANNUNG UND FREQUENZ LIEFERBAR - (*) OHNE EINSTELLBAREM BYPASS-VENTIL