



SYSTÈMES DE GESTION DU CARBURANT



DISTRIBUTEURS



KITS



POMPES



COMPTEURS



PISTOLETS

PANTHER DC

CARACTÉRISTIQUES

- STRUCTURE SOLIDE
- FACILE À INSTALLER
- CONCEPTION COMPACTE
- IP55

PANTHER DC est une pompe à ailettes à amorçage automatique rotative adaptée pour toutes les applications nécessitant des débits importants. Cet équipement est doté d'un filtre intégré (500 µ) et d'une vanne de dérivation. La version 24/12 V peut être utilisée avec les deux tensions.

PERFORMANCES

JUSQU'À

70 L/MIN

DÉBIT

12/24V

TENSION

30 MIN

CYCLE DE SERVICE



PANTHER DC



PACKAGING

CODE	PESO		PACKAGING		
	KG	LBS	MM	INCH	PCS/BOÎTE
FO034000B	7,5	16,5	345X175X255	13,6X6,9X10	1
FO034001C	7,5	16,5	345X175X255	13,6X6,9X10	1
FO034100C	7,5	16,5	345X175X255	13,6X6,9X10	1
FO034101C	7,5	16,5	345X175X255	13,6X6,9X10	1
FO034116C	7,5	16,5	345X175X255	13,6X6,9X10	1



FILTRAGE



SURVEILLANCE
DES LIQUIDES



ENROULEUR



ACCESSOIRES



MERCHANDISE

PIUSI

BIS

ANY BIODIESEL

A

AIR

A

ANTIGEL

Ad

AdBlue®

B

BIODIESEL

D

DIESEL

F

ALIMENTATION

G

ESSENCE

G

GRAISSE

K

KÉROSÈNE

O

HUILE

W

EAU

W

LAVE-GLACE

GRAPHIQUE

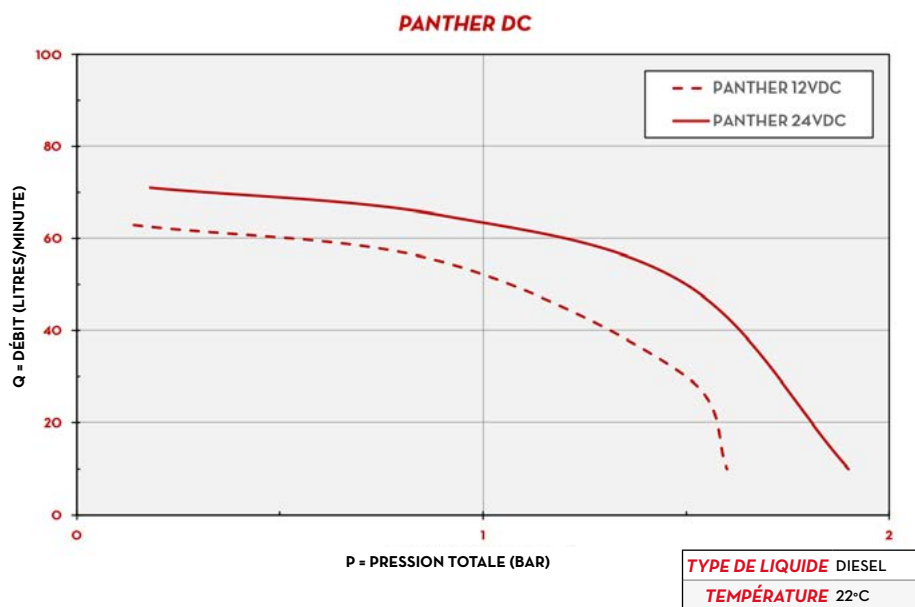

DIMENSIONS

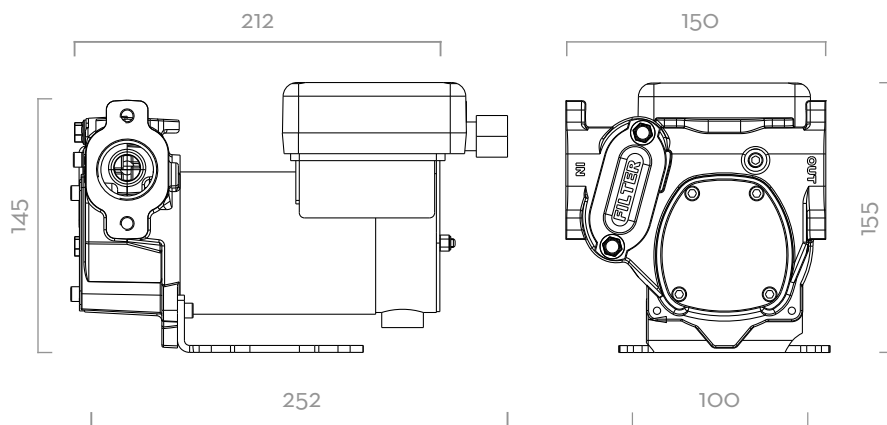

Dimensions exprimées en millimètres

CONTENU DE L'EMBALLAGE

- POMPE PANTHER DC
- MANUEL D'INSTRUCTIONS

DÉTAILS



MATÉRIAUX

- CORPS: FONTE
- ROTOR: ACIER FRITTÉ
- AUBES: RÉSINE ACÉTALE
- MOTEUR: BOÎTIER EN ALUMINIUM



POMPE

- MAX. 6 M (20 FT),
- TUYAU D'ASPIRATION Ø 1" MIN,
- HAUTEUR D'ASPIRATION MAX:
 - 2M (7FT) SANS CLAPET ANTI-RETOUR
 - 4M (14FT) AVEC CLAPET ANTI-RETOUR



RÉSERVOIR

DONNÉES TECHNIQUES

CODE	DESCRIPTION	TYPE DE LIQUIDES	DÉBIT		TENSION			CYCLE DE SERVICE MINUTES	RPM	SORTIE BSP
			L/MIN	GPM	DC VOLT	PUISSANCE WATT	AMP. MAX.			
FO034000B	PANTHER DC 12V	D	56	14,8	12	300	35	30	2900	1"
FO034001C	PANTHER DC 12V W/CABLE 2MT W/PLIERS	D	56	14,8	12	300	35	30	2900	1"
FO034100C	PANTHER DC 24/12V	D	70 / 35	18,5 / 9,2	24/12	420 / 150	25 / 16	30	3600 / 1800	1"
FO034101C	PANTHER DC 12/24V W/CABLE 2MT W/CLIPS	D	70 / 35	18,5 / 9,2	24/12	420 / 150	25 / 16	30	3600 / 1800	1"
FO034116C	PANTHER DC 12/24V W/CABLE 4MT W/CLIPS	D	70 / 35	18,5 / 9,2	24/12	420 / 150	25 / 16	30	3600 / 1800	1"