



FUEL MANAGEMENT SYSTEMS



DISPENSERS



KITS



PUMPS



METERS



NOZZLES

# K600 B/3

## FEATURES

- BETTER VISIBILITY
- ADJUSTABLE FLANGES
- ROTATING DISPLAY
- STANDARD BATTERY
- PULSE-OUT VERSION AVAILABLE
- IP66

The PIUSI K600 B/3 is an oval gear meter suitable for monitoring the delivery of diesel, biodiesel and antifreeze. This special version includes a large 80mm built-in digital display that can be rotated to suit every application. Among its features: 5-digit partial total and resettable total. Pulser version available.

### PERFORMANCE

UP TO <b>10-100 L/MIN</b>	<b>30 BAR</b> MAX
FLOW RATE	OPERATING PRESSURE
<b>± 0,5%</b>	<b>0,2%</b>
ACCURACY	REPEATABILITY



K600 B/3 METER



K600 B/3 B100



### PACKAGING

CODE	WEIGHT		PACKAGING		
	KG	LBS	MM	INCH	PCS/BOX
FOO491000	2	4,4	200X120X140	7,9X4,7X5,5	1
FOO491000	2	4,4	200X120X140	7,9X4,7X5,5	1
FOO492000	2	4,4	200X120X140	7,9X4,7X5,5	1



FILTRATION



TANK MONITORING



HOSE REEL



ACCESSORIES



MERCHANDISE

# PIUSI



ANY BIODIESEL



AIR



ANTIFREEZE



AdBlue®



BIODIESEL



DIESEL



FOOD



GASOLINE



GREASE



KEROSENE



OIL



WATER



WINDSCREEN

## CHART

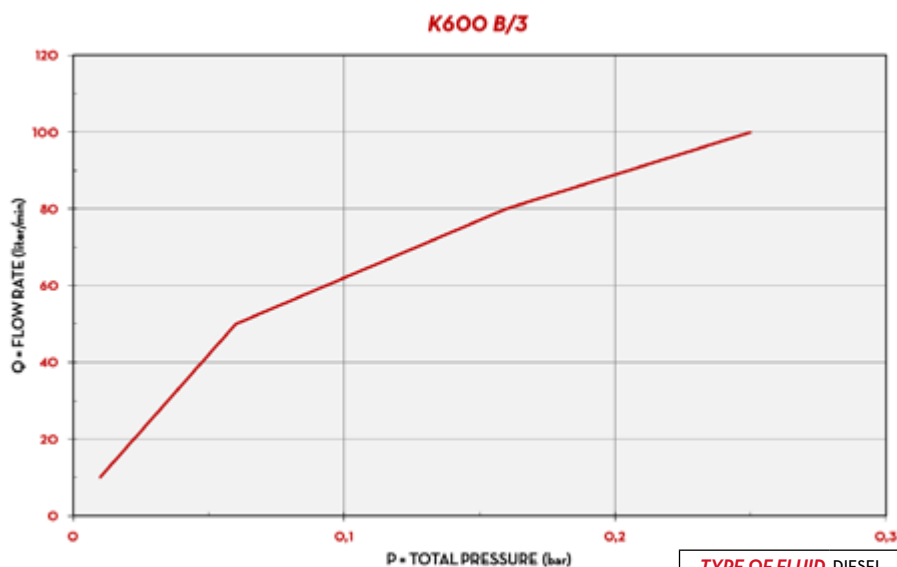

**TYPE OF FLUID** DIESEL  
**TEMPERATURE** 16°C

## DIMENSIONS

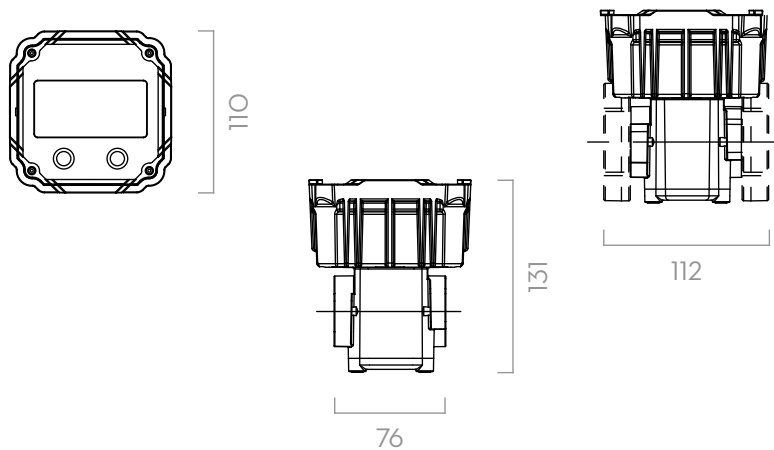

Dimensions expressed in millimeters

## IN THE BOX

- K600 B/3 METER
- FLANGES
- INSTRUCTION MANUAL

## DETAILS



## MATERIALS

- BODY: ALUMINIUM
- GEARS: TECHNOPOLYMER

## TECHNICAL DATA

CODE	DESCRIPTION	FLUIDS TYPE	FLOW RATE		PRESSURE		BATTERY	FLANGE	INLET / OUTLET	INLET FILTER
			L/MIN	GPM	BAR	PSI	N°2 X 1,5V (INCLUDED)			
FOO491000	K600 B/3 METER 1" BSP		10 - 100	2,64 - 26,4	30	426	YES	YES	1" BSP	YES
FOO492000	K600 B / 3 1" BSP PULS OUT		10 - 100	2,64 - 26,4	30	426	YES	YES	1" BSP	YES
FOO492B00	K600 B/3 1" BSP PULS OUT B100		10 - 100	2,64 - 26,4	30	426	YES	YES	1" BSP	YES

UPON REQUEST AVAILABLE IN NPTF VERSION AND DISPLAY IN GALLON/QUARTER OR PRINT