



FUEL MANAGEMENT
SYSTEMS



DISPENSERS



KITS



POMPE



CONTALITRI



PISTOLE

K600 B/3

CARATTERISTICHE

- VISIBILITÀ MIGLIORE
- FLANGE REGOLABILI
- DISPLAY GIREVOLE
- BATTERIA STANDARD
- DISPONIBILE VERSIONE CON USCITA A IMPULSI
- IP66

K600 B/3 di PIUSI è un contaltri a ingranaggi ovali adatto per monitorare l'erogazione di diesel, biodiesel e antigelo. Questa versione speciale include un display digitale integrato da 80 mm che può essere ruotato per adattarsi ad ogni applicazione. Tra le sue caratteristiche: totale parziale a 5 cifre e totale azzerabile. Disponibile versione pulser.

PERFORMANCE

FINO A 10-100 L/MIN	MAX 30 BAR
PORTATA	PRESSIONE D'ESERCIZIO
± 0,5%	0,2%
PRECISIONE	RIPETIBILITÀ



K600 B/3 METER



K600 B/3 WITH PULSE-OUT

PACKAGING

CODICE	PESO		PACKAGING		
	KG	LBS	MM	INCH	PCS/BOX
FOO491000	2	4,4	200X120X140	7,9X4,7X5,5	1
FOO491000	2	4,4	200X120X140	7,9X4,7X5,5	1
FOO492000	2	4,4	200X120X140	7,9X4,7X5,5	1



FILTRAZIONE



MONITORAGGIO FLUIDI



ARROTOLATORI



ACCESSORI



MERCHANDISE

PIUSI

ANY BIODIESEL



ARIA



ANTIGELO



AdBlue®



BIODIESEL



DIESEL



ALIMENTI



BENZINA



GRASSO



KEROSENE



OLIO



ACQUA



LAVAVETRI

GRAFICO

TIPO DI FLUIDO DIESEL

TEMPERATURA 16°C

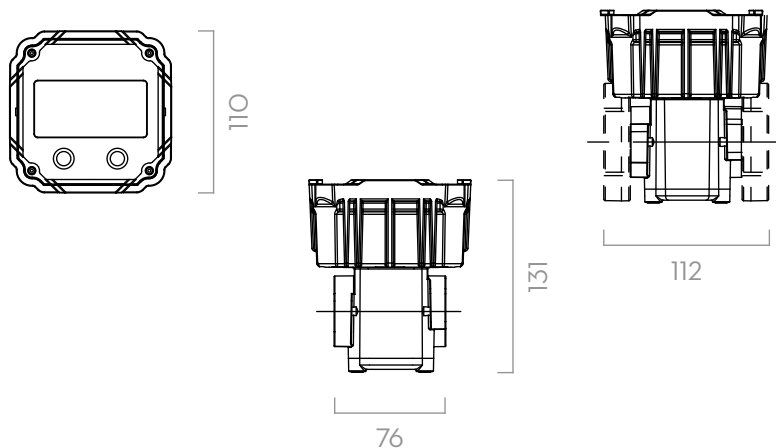
DIMENSIONI

Dimensioni espresse in millimetri

DENTRO LA SCATOLA

- CONTALITRI K600 B/3
- FLANGE
- MANUALE ISTRUZIONI

DETTAGLI

DISPLAY A 5 CIFRE



INGRANAGGI OVALI



DISPLAY GRANDE E GIREVOLE

MATERIALI

- CORPO: ALLUMINIO
- INGRANAGGI: TECNOPOLIMERO

DATI TECNICI

CODICE	DESCRIZIONE	TIPO DI FLUIDO	PORTATA		PRESSIONE		BATTERIA N°2 X 1,5V (INCLUSA)	FLANGE	BSP INGRESSO / OUTLET	INGRESSO FILTER
			L/MIN	GPM	BAR	PSI				
FOO491000	K600 B/3 METER 1" BSP	D	10 - 100	2,64 - 26,4	30	426	SI	SI	1" BSP	SI
FOO492000	K600 B / 3 1" BSP PULS OUT	D	10 - 100	2,64 - 26,4	30	426	SI	SI	1" BSP	SI
FOO492B00	K600 B/3 1" BSP PULS OUT B100	D	10 - 100	2,64 - 26,4	30	426	SI	SI	1" BSP	SI

A RICHIESTA DISPONIBILE IN VERSIONE NPTF E DISPLAY IN GALLONI O STAMPA