

## Flügelpumpen A3

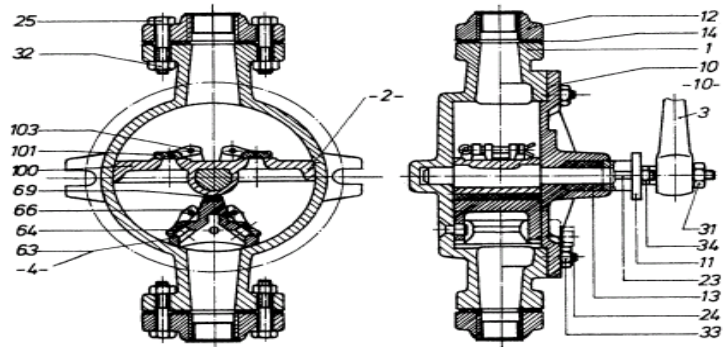

Flügelpumpe	Bezeichnung				Pos.	Stück	Ident-Nr.	Benennung	Werkstoff
	Ident-Nr.	A3-GGMS-OH	A3-GGMS-HH	A3-GGMS-GH					
	12967								
		11							
			49686						
				49					
	●	●	●	●	1	1	194	Pumpengehäuse BG A3	EN-GJL-250
	○	●			3	1	304	Hebel 3-4	GTW/Holz
	○		●	●			48111	Hebel 3-4	EN-GJL-250/Kst
	●	●	●	●	10	1	19926	Deckel 3	EN-GJL-250
	●	●	●	●	11	1	213	Stopfbuchsrille 3-4	EN-GJL-250
	●	●	●	●	12	2	281	Zweischrauben-Flansch DN 32 ø 78	EN-GJL-250
	E	E	E	E	13	1	218	Stopfbuchspackung 5-teilig, 5 x 5 x 80	Merkel 4386
	●	●	●	●		1	43830	Stopfbuchspackung 4-teilig, 5 x 5 x 80	Merkel 4386
	●	●	●	●	14	2	9505	Dichtung 50 x 78 x 1,5, DIN 71511	EWP 210, asbestfrei
	E	E	E	E	23	2	14040	Stiftschraube M8 x 50 DIN 939	5.8
	●	●	●	●		2	9079	Stiftschraube M8 x 40 DIN 939	5.8
	E	E	E	E	24	6	13794	Sechskantschraube M8 x 25 DIN EN 24018	4.6
	●	●	●	●		6	13925	Sechskantschraube M8 x 20 DIN EN 24017	8.8
	●	●	●	●	25	4	7853	Sechskantschraube M10 x 40 DIN EN 24018	4.6
	●	●	●	●	31	1	12276	Sechskantmutter M12 DIN EN 24034	5
	●	●	●	●	32	4	12274	Sechskantmutter M10 DIN EN 24034	5
	E	E	E	E	33	6	12272	Sechskantmutter M8 DIN EN 24034	5
	●	●	●	●	34	2	12272	Sechskantmutter M8 DIN EN 24034	5
	●	●	●	●	63	1	23809	Ventilsitz S3-4	GK-CuZn 37 Pb
	●	●	●	●	64	2	249	Ventilklappe 3-4	CuZn 39 Pb 3
	●	●	●	●	66	2	43931	Splint 3,2 x 45 DIN 94	MS
	●	●	●	●	69	1	272	Dichtleiste 3-4	Wollfilz
	●	●	●	●	100	1	23330	Antriebswelle mit Flügel 3	GK-CuZn 37 Pb/St
	●	●	●	●		1	19974	Antriebswelle mit Flügel 3	GK-CuZn 37 Pb/St
	●	●	●	●	103	2	43931	Splint 3,2 x 45 DIN 94	MS
<b>Montierte Baugruppen</b>									
	●	●	●	●	-2-	1	19905	Flügel BG A3-MS St (Teile 100, 103)	
	●	●	●	●		1	224	Flügel BG A3-MS St (Teile 100, 103)	
	●	●	●	●	-4-	1	238	Ventilsitz S BG AC3-4-MS (Teile 63, 64, 66, 69)	
	●	●	●	●	-10-	1	203	Deckel VGR A3-GGMS (Teile 10, 23, 34)	

- = Standard
- = Verwendung möglich
- E = nur als Ersatzteil für Pumpen vor 1986