

Flügelpumpen A1
und als Faßpumpen
Ausführung 12 und 13

Pumpe	Flügelpumpe				Faßpumpe	
	Bezeichnung	Ident-Nr.	Bezeichnung	Ident-Nr.	Bezeichnung	Ident-Nr.
	A1-GGMS-OH	12957	A1-GGMS-HH	12958	A1-GGMS-GH	5
	A1-GGMS-GH	363	A1-GGMS-GH	61	A1-GGMS-GH	68

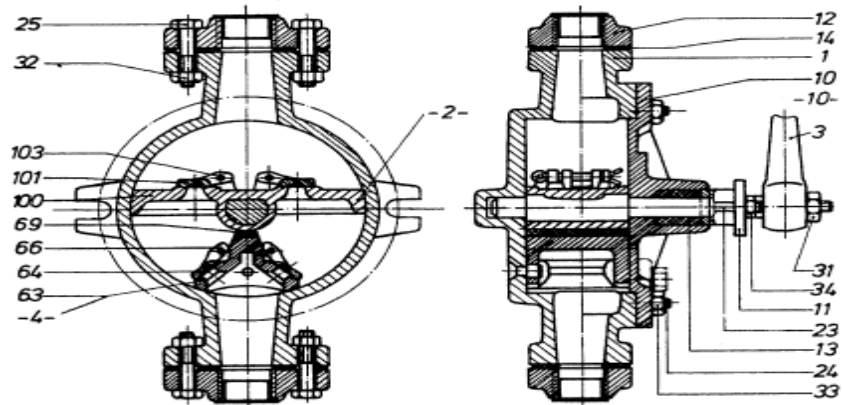

						Pos.	Stück	Ident-Nr.	Benennung	Werkstoff
●	●	●	●	●	●	1	1	192	Pumpengehäuse BG A1	EN-GJL-250
○	○	○	○	○	○	3	1	302	Hebel 01	GTW/Holz
○	○	○	○	○	○	100	1	300	Hebel 01	EN-GJL-250/Kst
●	●	●	●	●	●	10	1	18231	Deckel 1	EN-GJL-250
●	●	●	●	●	●	11	1	211	Stopfbuchsbrille 1	EN-GJL-250
●	●	●	●	●	●	12	2	279	Zweischr. Flansch DN 20 e 58	EN-GJL-250
						2	2	18237	Zweischr. Flansch DN 20 e 58	EN-GJL-250
E	E	E	E	E	E	13	1	217	Stopfbuchspackung 7-teilig, 4 x 4 x 60	Merkel 4386
●	●	●	●	●	●	1	1	47797	Stopfbuchspackung 5-teilig, 4 x 4 x 60	Merkel 4386
●	●	●	●	●	●	14	2	500561	Dichtung 35 x 58 x 2	EWP 210, asbestfrei
E	E	E	E	E	E	23	2	207	Stiftschraube M8 x 45	5.8
●	●	●	●	●	●	2	2	9079	Stiftschraube M8 x 40	5.8
E	E	E	E	E	E	24	6	13794	Sechskantschraube M8 x 25	4.6
●	●	●	●	●	●	6	6	41904	Sechskantschraube M8 x 16	8.8
●	●	●	●	●	●	25	4	288	Sechskantschraube M8 x 35	4.6
●	●	●	●	●	●	31	1	12274	Sechskantmutter M10	5
●	●	●	●	●	●	32	4	12272	Sechskantmutter M8	5
E	E	E	E	E	E	33	6	12272	Sechskantmutter M8	5
●	●	●	●	●	●	34	2	12272	Sechskantmutter M8	5
●	●	●	●	●	●	63	1	18244	Ventilsitz S1	GK-CuZn 37 Pb
●	●	●	●	●	●	64	2	246	Ventilklappe 1	CuZn 39 Pb 3
●	●	●	●	●	●	66	2	43930	Splint 3,2 x 36 DIN 94	MS
●	●	●	●	●	●	69	1	269	Dichtleiste 01	Wolffiz
●	●	●	●	●	●	101	2	246	Ventilklappe 1	CuZn 39 Pb 3
●	●	●	●	●	●	103	2	43930	Splint 3,2 x 36 DIN 94	MS
						140*	1	113	Saugrohr 3/4" 800 lg	St 33
						141*	1	135	Auslaufrohr 3/4" 311 lg	St 33
						142*	1	139	Standrohrverschraubung 3/3 3/4"	MS
						148*	1	166	Haken	GK-CuZn 37 Pb/St
						149*	1	118	Faßspund B3/4"	EN-GJL-250
						150*	1	143	Langer Bogen 3/4"	G4
Montierte Baugruppen										
●	●	●	●	●	●	-2-	1	222	Flügel BG A1-MS St (Teile 101, 103)	
●	●	●	●	●	●	-4-	1	232	Ventilsitz BG A1-MS (Teile 63, 64, 66, 69)	
●	●	●	●	●	●	-10-	1	18225	Deckel VGR A1 (Teile 10, 23, 24)	

- = Standard
- = Verwendung möglich
- E = nur als Ersatzteil für Pumpen vor 1986
- * = bildlich nicht dargestellt