



KITS



PUMPEN



ZÄHLER



ZAPFVENTILZÄHLER



ZAPFVENTILE



ALTÖLAUSRÜSTUNG

CAMBIAOLIO

MERKMALE

- IDEAL FÜR KLEINE WERKSTÄTTEN
- KEINE DRUCKLUFT ERFORDERLICH
- WIRD MIT 6 SAUGSONDEN GELIEFERT
- VIELSEITIG
- VAKUUMANZEIGE
- 5 M KABEL
- AUFFANGTANK MIT MESSSKALA
- LEICHT ENTLEERBAR

Der CAMBIAOLIO ist das traditionelle Angebot, das Piusi für den perfekten Ölwechsel ohne die Notwendigkeit von Druckluft bereitstellt. Dieses kleine Gerät wird auf einem Wagen geliefert, mit dem es überallhin transportiert werden kann.

LEISTUNGSPARAMETER

BIS ZU

10L

FASSUNGSVERMÖGEN DES TANKS

AC

SPANNUNG

LEISTUNG

UNTER

70DB

GERÄUSCHPEGEL



CAMBIAOLIO

VERPACKUNG

CODE	GEWICHT		VERPACKUNG			
	KG	LBS	MM	ZOLL	STCK./PALETTE	STCK./KARTON
FO05000B	19,5	43	600X290X300	23,6X11,4X11,8		1



FILTERUNG



ÖLÜBERWACHUNG



TANKÜBERWACHUNG



SCHLAUCHAUFROLLER



ZUBEHÖR



MERCHANDISE



LUFT



FROSTSCHUTZ



AdBlue®



BIODIESEL



DIESEL



LEBENS.M.



BENZIN



SCHMIERM.



KEROSIN



ÖL



WASSER



WISCHERFLÜSS.

ABMESSUNGEN

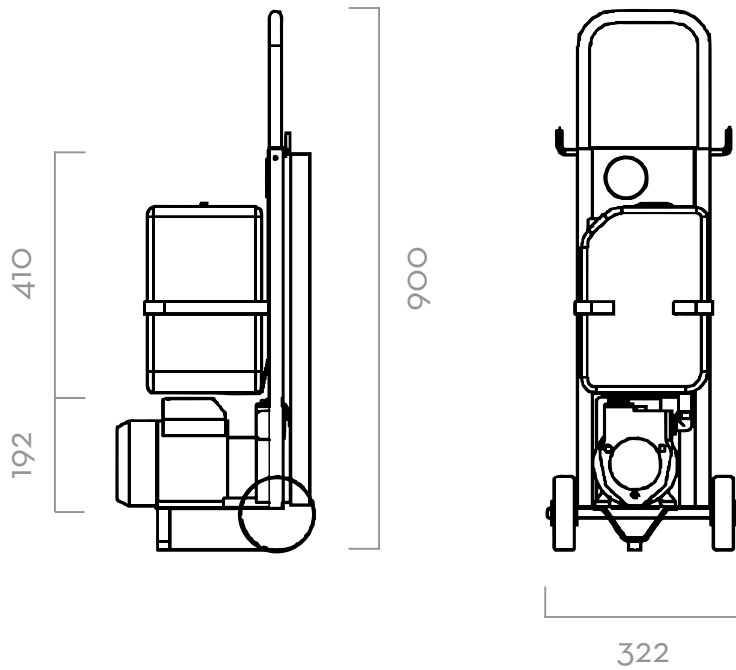

Maße in Millimetern

LIEFERUMFANG

- CAMBIAOLIO
- BEDIENUNGSANLEITUNG

EINZELHEITEN



MATERIALIEN

- PUMPENGEHÄUSE: GUSSEISEN
- PUMPENZAHRÄDER: BRONZE
- WELLE: STAHL

TECHNISCHE DATEN

CODE	BESCHREIBUNG	FLÜSSIGKEITSART	VOLUMENSTROM		SPANNUNG			TANK	
			L/MIN	GPM	AC V./HZ DC V.	POWER WATT	AMP. MAX.	LITER	GAL
FO050000B	CAMBIAOLIO M	🟡	2 - 10	0,5 - 2,5	230/50-60	350	2	10	3