



KITS



POMPES



COMPTEURS



PISTOLETS COMPTEURS



PISTOLETS



ÉQ. HUILES USAGÉES

# CAMBIAOLIO

## CARACTÉRISTIQUES

- IDÉAL POUR LES PETITS ATELIERS
- PAS D'AIR COMPRIMÉ NÉCESSAIRE
- 6 SONDES D'ASPIRATION INCLUSES
- POLYVALENT
- INDICATEUR DE VIDE
- 5 MÈTRES DE CÂBLE
- RÉSERVOIR DE COLLECTE GRADUÉ
- FACILE À VIDER

CAMBIAOLIO est l'offre traditionnelle de PIUSI pour une vidange d'huile parfaite sans air comprimé. Ce petit équipement est installé sur un chariot et peut ainsi être transporté n'importe où.

### PERFORMANCES

JUSQU'À

**10L**

CAPACITÉ RÉSERVOIR

**AC**

TENSION

MOINS DE

**70DB**

NIVEAU DE BRUIT



CAMBIAOLIO

### PACKAGING

CODE	POIDS		PACKAGING			
	KG	LBS	MM	INCH	PCS/PALLET	PCS/BOÎTE
FO05000B	19,5	43	600X290X300	23,6X11,4X11,8		1



FILTRAGE



SISTÈME DE GESTION DES FLUIDES



SURVEILLANCE DES LIQUIDES



ENROULEURS



ACCESSOIRES



MERCANDISE



AIR



ANTIGEL



AdBlue®



BIODIESEL



DIESEL



ALIMENTATION



ESSENCE



GRAISSE



KÉROSÈNE



HUILE



EAU



LAVE-GLACE

## DIMENSIONS

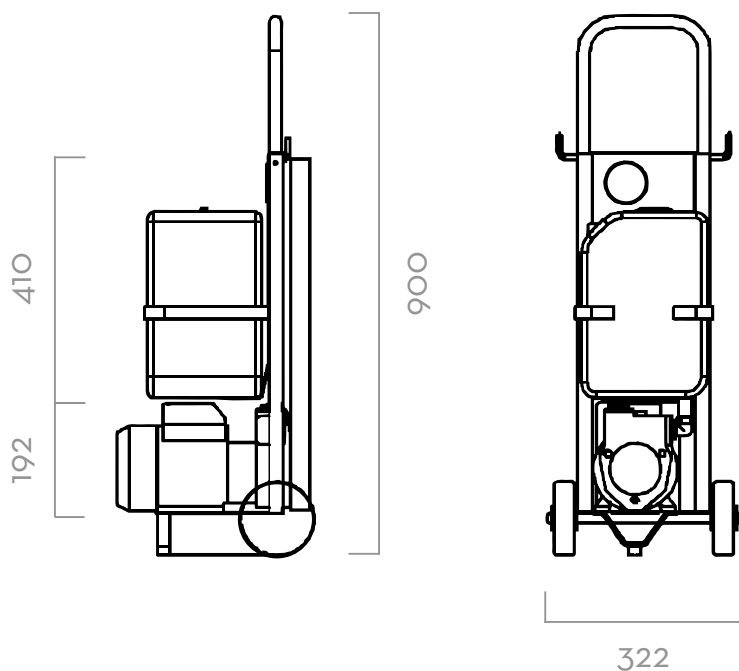

Dimensions exprimées en millimètres

## CONTENU DE L'EMBALLAGE

- CAMBIAOLIO
- MANUEL D'INSTRUCTIONS

## DÉTAILS



ON/OFF INTERRUPTEUR



JAUGE DE PRESSION



RÉSERVOIR 10 LITRES

## MATÉRIAUX

- CORPS POMPE: FONTE
- ENGRENAGES POMPE: BRONZE
- ARBRE: ACIER

## DONNÉES TECHNIQUES

CODE	DESCRIPTION	TYPE DE LIQUIDES	DÉBIT		TENSION			RÉSERVOIR	
			L/MIN	GPM	AC V/HZ DC VOLT	PPUISSANCE WATT	AMP. MAX.	LITRE	GAL
FO050000B	CAMBIAOLIO M		2 - 10	0,5 - 2,5	230/50-60	350	2	10	3