



KITS



POMPE



CONTALITRI

PISTOLE
CONTALITRI

PISTOLE

ATTREZZATURE
OLIO ESAUSTO

CAMBIAOLIO

CARATTERISTICHE

- IDEALE PER PICCOLE OFFICINE
- NON È NECESSARIA ARIA COMPRESSA
- 6 SONDE DI ASPIRAZIONE INCLUSE
- VERSATILE
- INDICATORE VUOTO
- 5 METRI DI CAVO
- SERBATOIO DI RACCOLTA GRADUATO
- FACILE DA SVUOTARE

CAMBIAOLIO è la proposta tradizionale di PIUSI per un cambio olio perfetto senza bisogno di aria compressa. Di dimensioni compatte, CAMBIAOLIO è carrellato, quindi trasportabile ovunque.

PERFORMANCE

FINO A

10L

CAPACITÀ FUSTO

AC

VOLTAGGIO

POTENZA

INFERIORE A

70DB

LIVELLO RUMORE



CAMBIAOLIO

PACKAGING

CODICE	PESO		PACKAGING			
	KG	LBS	MM	INCH	PEZZI/PALLET	PEZZI/BOX
FO05000B	19,5	43	600X290X300	23,6X11,4X11,8		1



FILTRAZIONE



MONITORAGGIO FLUIDI



MONITORAGGIO SERBATOI



ARROTATORI



ACCESSORI



MERCHANDISE



ARIA



ANTIGELO



AdBlue®



BIODIESEL



DIESEL



ALIMENTI



BENZINA



GRASSO



KEROSENE



OLIO



ACQUA



LAVAVETRI

DIMENSIONI

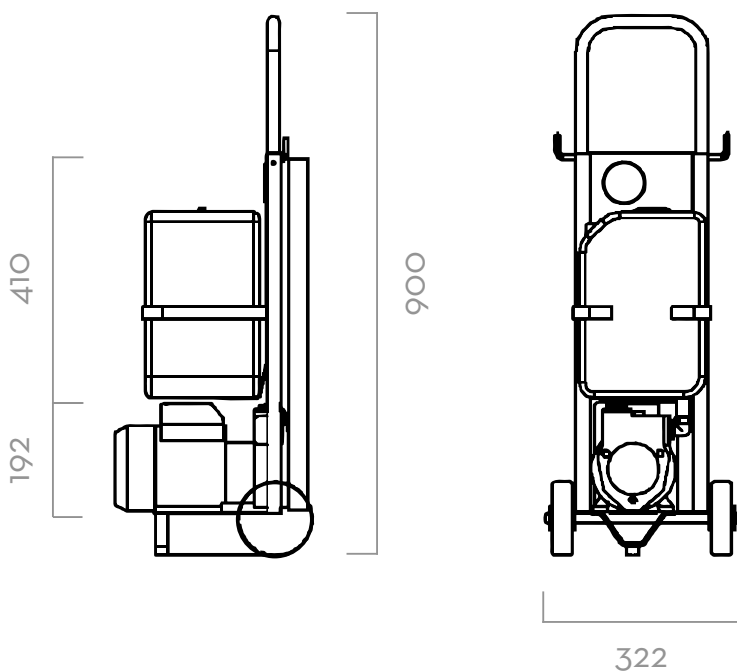

Dimensioni espresse in millimetri

DENTRO LA SCATOLA

- CAMBIAOLIO
- MANUALE ISTRUZIONI

DETTAGLI



SELETTORE ON/OFF



MANOMETRO



SERBATOIO DA 10 LITRI

MATERIALI

- CORPO POMPA: GHISA
- INGRANAGGI POMPA: BRONZO
- ALBERO: ACCIAIO

DATI TECNICI

CODICE	DESCRIZIONE	TIPO DI FLUIDO	PORTATA		VOLTAGGIO			SERBATOIO	
			L/MIN	GPM	AC V/Hz DC VOLT	POTENZA WATT	AMP. MAX.	LITRI	GAL
FO050000B	CAMBIAOLIO M		2 - 10	0,5 - 2,5	230/50-60	350	2	10	3